

AISI 316 TRE PEZZI FF - IVR 665



Valvola a sfera a passaggio totale in tre pezzi in acciaio inox AISI316.
 Attacchi filettati gas F/F - Flangetta ISO 5211.

*AISI316 stainless steel three pieces full bore ball valve.
 Threaded ends F/F - ISO 5211 top for actuator.*

Vanne à sphère à passage integral trois pieces en acier inox AISI316.
 Taraudage pas gaz F/F - Platine ISO 5211.

*Kugelhahn mit vollem Durchgang aus Edelstahl AISI316.
 Anschlussgewinde I/I - Flansch ISO 5211.*



IMPIEGHI: Le valvole a sfera serie 665 sono adatte per impianti industriali, chimici ed alimentari.

APPLICATIONS: The 665 series are suitable for use in industrial, chemical and food plants.

N. N.	DENOMINAZIONE PART NAME	MATERIALE MATERIAL	TRATTAMENTO TREATMENT
1	Corpo - Body	AISI316	
2	Manicotto - Body end	AISI316	
3	Seggio - Seat	PTFE caricato 15% vetro PTFE 15% glassfiber	
4	Guarniz. corpo - Body seal	PTFE	
5	Sfera - Ball	AISI316	
6	Asta - Stem	AISI316	
7	Rondella - Washer	PTFE	
8	Guarn. asta - Stem seat	PTFE	
9	Premistoppa - Packing nut	AISI304	
10	Maniglia - Handle	AISI304	Rivestimento PVC - PVC coated
11	Bloccaggio - Locking	AISI304	
12	Dado - Nut	AISI304	
13	Arresto - Stop pin	AISI304	
14	Dado - Nut	AISI304	
15	Bullone - Bolt	AISI304	

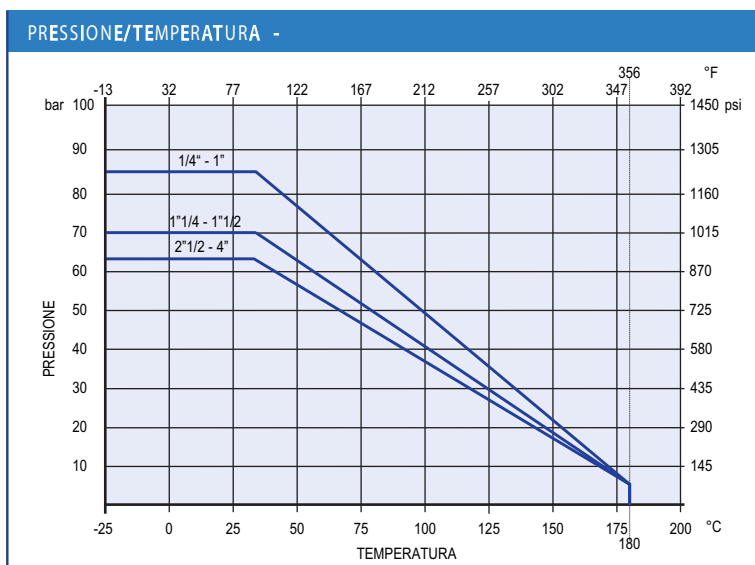
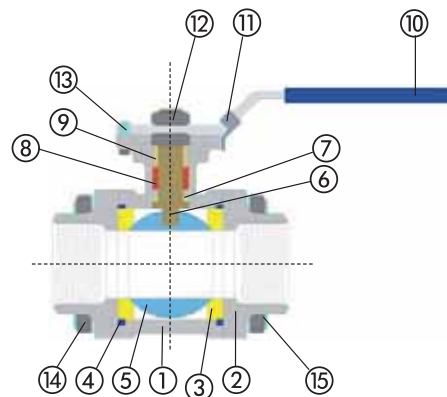

DATI TECNICI - TECHNICAL DATA

Pressione massima di esercizio Max working pressure	1/4" - 1" 1 1/4" - 1 1/2" 2" - 4"	85 bar 70 bar 60 bar
Temperatura massima di esercizio Max working temperature		-25°C + 180°C
Filettatura estremità Threaded ends		UNI ISO 7/1 R
Asta antiscoppio Anti blow-out stem		
Asta con testa quadra 45° Stem with square head 45°		ISO5211.73
A richiesta: On request:	filettatura thread	NPT ANSI B.1.20.1

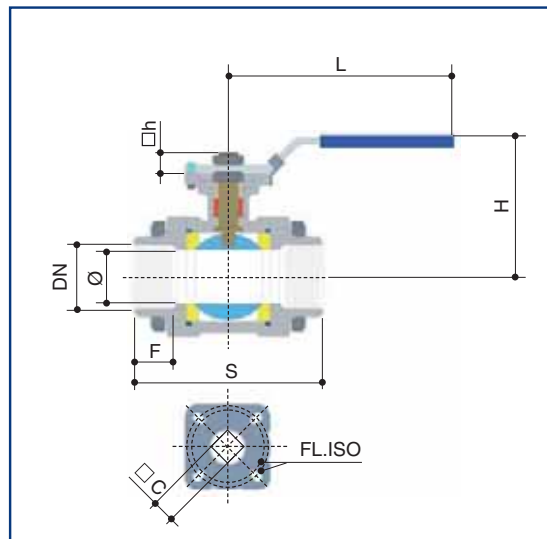

DN	1/4"	3/8"	1/2"	3/4"	1"	1"1/4	1"1/2	2"	2"1/2	3"	4"
Ø	11	12.7	15	20	25	32	40	50	65	80	100
S	48	48	55	74	81	91	103	120	151	182	220
F	10	11	15	16	19	21	21	25	30	33	39
H	60	60	65	72	75	90	95	105	140	165	170
L	117	117	117	135	140	203	203	203	260	260	280
FLISO	F03	F03	F03/04	F04/05	F04/05	F05/07	F05/07	F05/07	F07/10	F07/10	F07/10
□ C	9	9	9	11	11	14	14	14	17	17	17
□ h	8	8	9	11	11	12.5	12.5	12	17	19	20

Dimensioni in mm - Dimensions in mm

DIAGRAMMA PERDITE DI CARICO - FLOW AND PRESSURE DROP

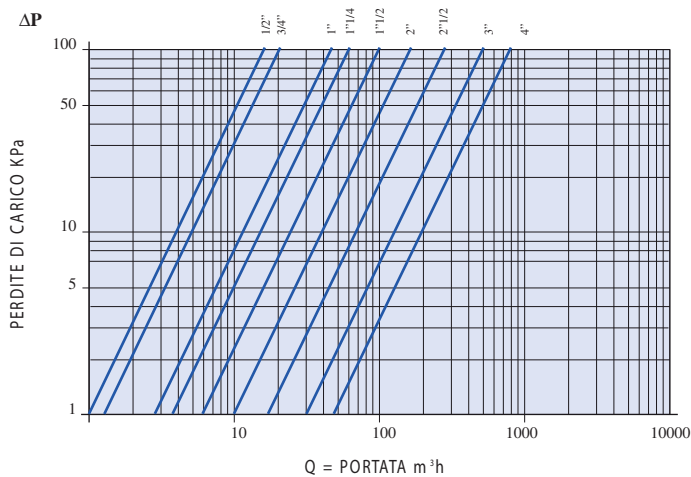

COEFFICIENTE KW - KW FACTOR

1/4"	15
3/8"	15
1/2"	20
3/4"	45
1"	60
1"1/4	100
1"1/2	170
2"	265
2"1/2	510
3"	790
4"	1230